



Download
Manual



Growatt New Energy

Shenzhen Growatt New Energy Technology CO.,LTD
No.28 Guangming Road, Shiyan Street, Bao'an District,
Shenzhen, P.R.China

T +86 0755 2747 1942

E service@ginverter.com

W www.ginverter.com

GR-UM-186-A-01



Installation & Operation Manual

Contents

1 Brief Introduction

- 1.1 Preface
- 1.2 Target Group
- 1.3 Product Description
- 1.4 Safety Instructions

2 Safety

- 2.1 Purpose Use
- 2.2 Safety Measure
- 2.3 Symbols introduction on the SPA inverter

3 Product Description

- 3.1 Growatt SPA series inverter
- 3.2 Label Explanation
- 3.3 Size and weight
- 3.4 The advantage of the unit of Growatt SPA

4 Unpacking

5 Installation

- 5.1 Basic installation requirements
- 5.2 Installation requires tools and RJ 45 terminal sequence of the LAN line
- 5.3 Installation Instructions
- 5.4 SPA System Connection Mode

6 Commissioning

- 6.1 Commissioning of SPA
- 6.2 Operation modes
- 6.3 Country setting
- 6.4 Display and button
- 6.5 Communication

7 Start-up and shut down SPA system

- 7.1 Start-up the SPA system
- 7.2 Disconnect the SPA system

8 Attention of the installation environment, maintenance and cleaning

9 Fault removal

10 EU Declaration of Conformity

11 Decommissioning

- 11.1 Dismantling the energy storage
- 11.2 Packing the SPA inverter
- 11.3 Storing SPA inverter
- 11.4 Disposing of the SPA inverter

12 Product specification

- 12.1 Growatt SPA series energy storage machine product specification
- 12.2 DC input terminal parameter
- 12.3 Torque
- 12.4 Appendix

13 Certificate

14 Contact

1 Brief Introduction

1.1 Preface

This manual will provide the users who use the Growatt SPA TL3 BH Series of Shenzhen Growatt New Energy Technology Co.,LTD(Short for Growatt as below) with the detailed product information and the installation instructions. Please read this manual carefully and put this manual on some place where is convenient to installation, operation, obtain. Any modifications of Growatt new energy, we will not notify the user.

1.2 Target Group

Growatt SPA TL3 BH inverter must be installed by professional electrical personnel who have obtained the certification of the relevant departments. We have two kinds of energy storage machine for different battery one is for lithium battery and the other is for lead-acid battery, we suggest: customer should decide which kind of energy storage machine you want, Growatt can provide only lithium battery with energy storage machine, customer can choose lead-acid energy storage machine with no battery provide by Growatt while they can buy these battery from market easily. Especially if customer choose energy storage system with lithium battery(which must be provide by Growatt) but used for lead-acid battery or used lead-acid battery for lithium battery model, it will be dangerous. Installer can install energy storage machine of Growatt SPA TL3 BH Series rapidly and troubleshooting, build communication system through read this manual carefully.If you have any questions in the process of installation, you can login in www.growatt.com and leave some message.Or you can call our 24-hour service hotline+86 0755 2747 1942.

1.3 Product Description

Growatt SPA TL3 BH Series is used to store energy generated by the photovoltaic cell panels or energy from grid if it is allowed in the battery, also energy can be sent to power grid through SPA TL3 BH for self consumption or when Grid power is lost, SPA TL3 BH can be used as backup power.

SPA series has six kinds of type:

- SPA 4000TL3 BH
- SPA 5000TL3 BH
- SPA 6000TL3 BH
- SPA 7000TL3 BH
- SPA 8000TL3 BH
- SPA 10000TL3 BH

Note: we describe this series as “SPA” as below.

Overview:

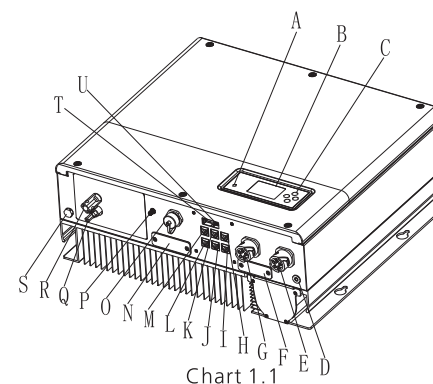

Chart 1.1

Position	Description
A	LED of status display
B	LCD screen
C	Function button
D	Ground point
E	EPS output(off grid connection)
F	RSD(do not open except by Professional staff)
G	AC Grid (on grid connection)
H	Rj45 interface of DRMs(used only in Australia)
I	NTC: Lead-acid temperature sensor terminal
J	RS485 communication interface of meter2(Reserved)
K	RS485 communication interface of Lithium battery
L	Rs485 communication interface of meter1
M	CAN communication interface of Lithium battery
N	RS232/Wi-Fi/shinelink cover board
O	USB interface
P	Antenna
Q	Battery terminal(negative)
R	Battery terminal(positive)
S	Breathable valve
T	DIP switch(set safety standard)
U	Dry contact

1.4 Safety Instructions

1. Please be clear which kind of battery system you want, lithium battery system or lead-acid battery system, if you choose the wrong system, SPA can't work normally.
2. Please read this manual carefully before the installation, The company has the right not to quality assurance. If not according to the instructions of this manual for installation and cause equipment damage.
3. All the operation and connection please professional electrical or mechanical engineer.
4. During installation, Please don't touch the other parts within the box.
5. All the electrical installation must comply with the local electrical safety standards.
6. If equipments needs to maintain, Please contact with local specify system installation and maintenance personnel.
7. Use the equipment to combined to grid needs to obtain the permission of local power supply department.

2 Safety

2.1 Purpose Use

The system chart of SPA:

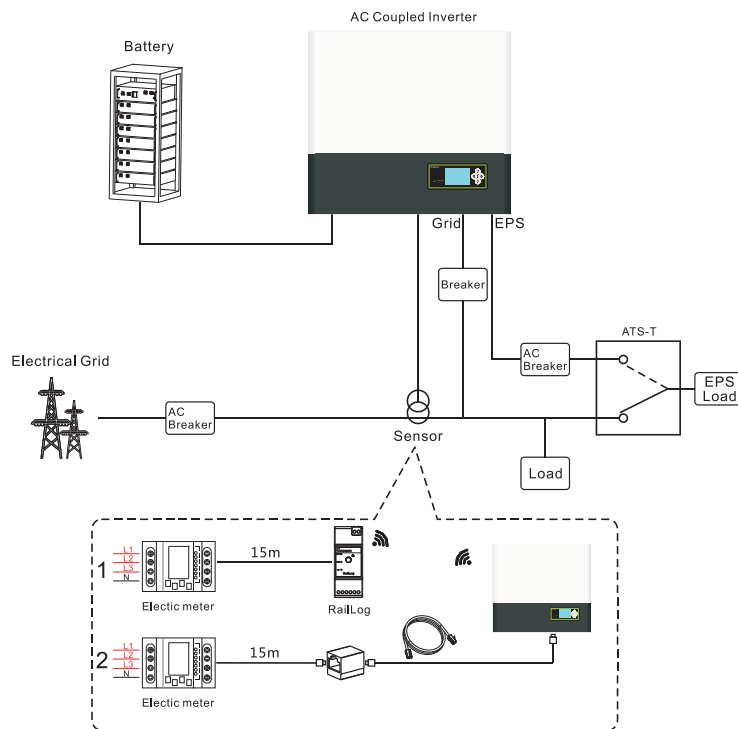

Chart 2.1

As shown above, a complete grid-connected system of SPA consists of SPA inverter, battery, utility grid and other components.

Attention:

As the system refer to battery use, We must make sure ventilation of the service environment and temperature control in order to prevent the danger of battery explosion, Battery recommended installation environment must be strictly in accordance with the specification, if the specification is IP20 environment, the pollution degree of the unit is PD2, meanwhile the temperature should be control in the 0-40°C of indoor ventilation and the humidity should be 5%-85%.

2.2 Safety Measure



Risk of high voltage!
Relevant operation for professional personnel.
Please notice children, disabled, laypeople do not close.
Supervise and make sure children don't play near the installation position of energy storage machine.



Risk of burns on the parts shell of SPA inverter!
During the work, Cover, shell around, radiator is likely to be hot.



SPA inverter exists radiation maybe affect health!
Don't stay a long time within 20cm range from SPA inverter.









SPA inverter ground connection

Please ensure SPA inverter ground connection is reliable for make sure people's safety.

2.3 Symbols introduction on the SPA inverter

Symbol	Description
	Caution: Risk of electrical shock!
	Caution : hot surface!

	Caution: risk of danger!
	Danger to life due to high voltage in SPA. There is residual voltage in SPA, SPA requires 5 minutes to discharge. Please wait 5 minutes before you open the upper lid or the DC lid.
	Protective conductor terminal
	Direct Current(DC)
	Alternating Current(AC)
	The machine complies with the requirements of the applicable CE guidelines
	Refer to the operating instructions.

3 Product Description

3.1 Growatt SPA series inverter

Marks of SPA

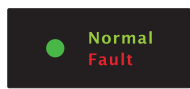
Mark	Description	Explanation	
	Push-button	Operation of display screen and set system	
	Status symbol of SPA	Green light on	SPA run normally
		Red light on	fault state
		Green light blinking	Alarm state
		Red light blinking	Software updating

3.2 Label Explanation

Label contains the following information: for example SPA 10000TL3 BH shows as below:

Growatt AC Coupled Inverter	
Model name	SPA 10000TL3 BH
AC output/input data	
Nominal input/output power	10000/10000 W
Max. output apparent power	10000 VA
Nominal voltage	3W/N/PE 230/400 a.c.V
Max. input/output current	15.2/15.2 a.c.A
Nominal Frequency	50/60 Hz
Power factor range	0.8leading~0.8lagging
Stand alone data	
Nominal AC output power	10000 W
Nominal AC output voltage	230/400 a.c.V
Nominal AC output Frequency	50/60 Hz
Battery data	
Battery voltage range	100-550 d.c.V
Max. charging and discharging current	25 d.c.A
Type of battery	Lithium / Lead-acid
Others	
Safety level	Class I
Ingress Protection	IP65
Operation Ambient Temperature	-25°C - +60°C
	

Description of label:

The type of product	Growatt SPA 10000TL3 BH
AC output/input data	
Nominal power	10000W
Max. apparent power	10000VA
Nominal voltage	3W/N/PE 230/400Vac
Max current	15.2A
Nominal Frequency	50Hz/60Hz
Power factor range	0.8 leading~0.8 lagging
Stand alone data	
Nominal AC output power	10000W
Nominal AC output voltage	230/400Vac
Nominal AC output Frequency	50Hz/60Hz
Battery data	
Battery voltage range	100~550Vdc
Max. charge and discharge current	25A
Type of battery	Lithium / Lead-acid
Others	
Safety level	Class I
Ingress Protection	IP65
Operation Ambient Temperature	-25°C~+60°C
Certificates Number	(For Australian models)

3.3 Size and weight

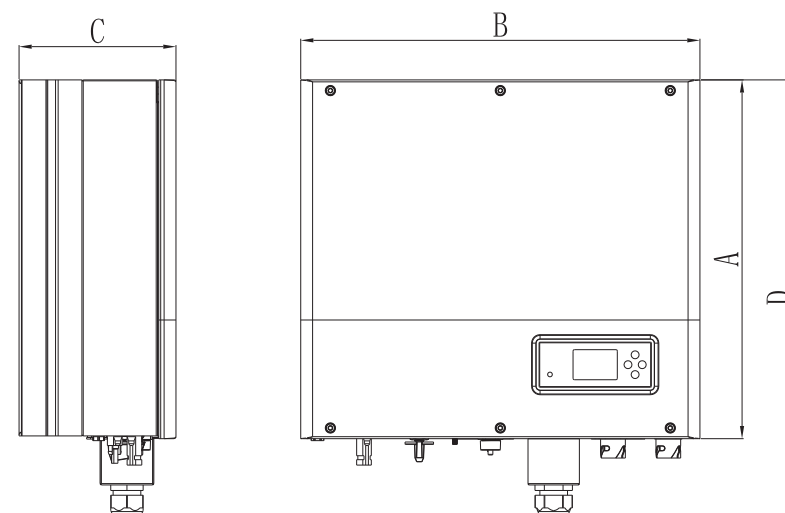

Chart 3.1

	A(mm)	B(mm)	C(mm)	weight(kg)
Growatt SPA TL3 BH	453	505	198	25

3.4 The advantage of the unit of Growatt SPA

Features below:

- All in one design. Can improve self consumption, back up and also pinch the valley.
- Smart management, work mode can be set.
- Safe battery used.
- Easy installation.
- Two mpp tracker input.

4 Unpacking and inspection

Before unpacking, please check whether there are any visible external damages. After unpacking, please check whether there are damages or missing of the parts, if it happen, please contact with supplier.
 Growatt SPA series and accessories shows as follows:

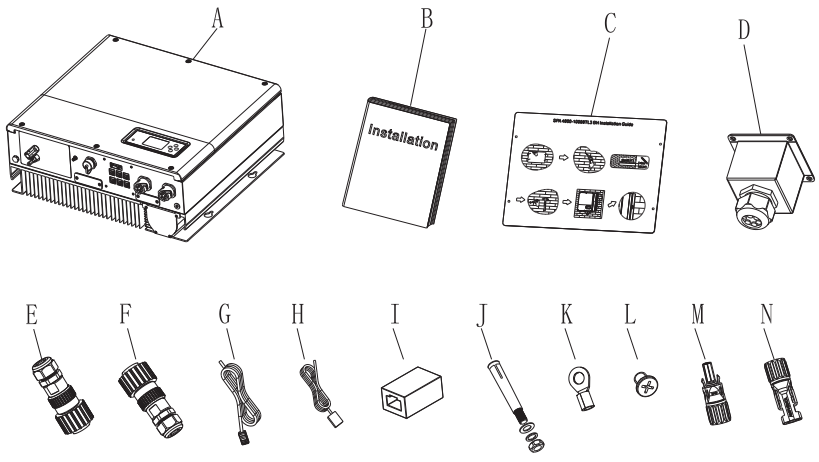

Chart 4.1

Item	Number	Description
A	1	SPA inverter
B	1	User Manual
C	1	Paper board(installation guide)
D	1	Waterproof cover
E	1	AC Grid connector
F	1	EPS output connector (red connector)
G	1	Communication cable
H	1	Lead-acid battery temperature sensor
I	1	RJ45 connector
J	4	M6 setscrew
K	1	Ground terminal
L	4	M4 setscrew
M/N	1/1	Mc4 connector (blue connector)

Installation 5

5.1 Basic installation requirements

- A. The installation location must be suitable for SPA's weight for a long period time.
- B. The installation location must conforms with dimension of SPA.
- C. Do not install the unit on structures constructed of flammable or thermo labile materials.
- D. The Ingress Protection rate is IP65 and the pollution degree is PD2. Please refer to the below:

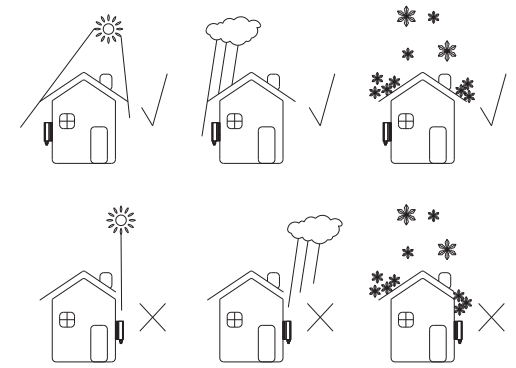

Chart 5.1

- E. Battery installation option is not far away from the position of SPA, the length between SPA and battery should not be more than 5m.
- F. The ambient temperature should be -25°C ~ 60°C.
- G. SPA can be installed in vertical or lean back on plane, Please refer to the below:

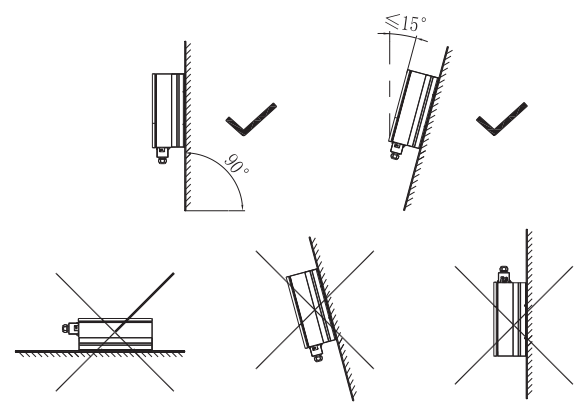

Chart 5.2

H. Installation position shall not prevent access to the disconnection means.
 I. In order to ensure machine can run normally and easy to operate, please pay attention to provide adequate space for SPA, Please refer to below:

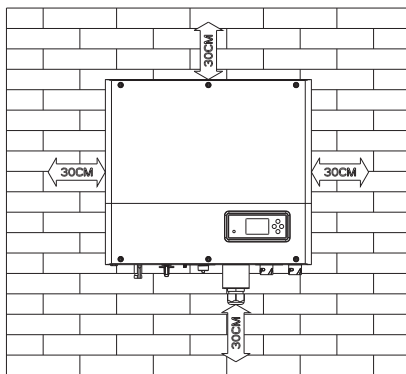

Chart 5.3

- J. Do not install the machine near television antenna or any other antennas and antenna cables.
- K. Don't install the machine in the living area.
- L. Be sure that the machine is out of the children's reach.
- M. Taking the battery fixing space into account, about the dimensions please reference user manual.
- N. The Inflammable and explosive dangerous goods must not be placed around battery in case of cause serious danger.

5.2 Installation requires tools and RJ 45 terminal sequence of the LAN line.

When installing, we need to use tools as follow, prepare the follow tools before installing:



Chart 5.4

No.	Description
1	Press the RJ45 terminal
2	Press battery terminal connector
3	Disconnect battery terminal
4	Unscrew nut
5	Unscrew screw
6	Knock expansion screw
7	Drill holes on the wall

LAN line RJ45 sequence as follow:

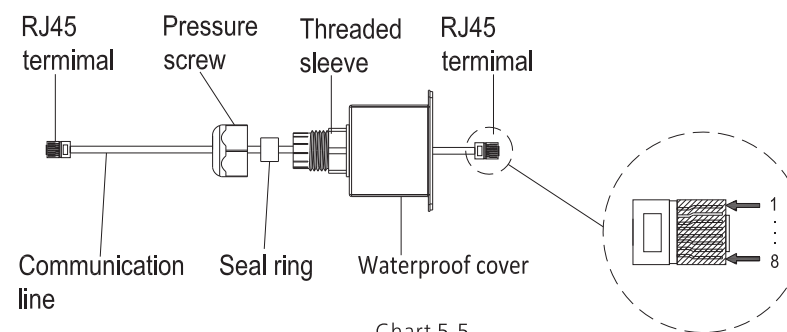

Chart 5.5



Chart 5.6

LAN line 1-8 colors as below:

PIN	1	2	3	4	5	6	7	8
Color	White orange	Orange	White green	Blue	White blue	green	White brown	brown

5.3 Installation Instructions

5.3.1 Attention Layout (length of sensors consider)

Growatt SPA4000-10000TL3 BH only use meter as its sensor, before installing your system you should know something as below:

1. The cable of meter is suggested not longer than 15m. Because of this, you should consider the cable length between SPA and combiner box.
2. The meter must installed in the L line.
3. The installation layout of energy storage system at home shows as following:

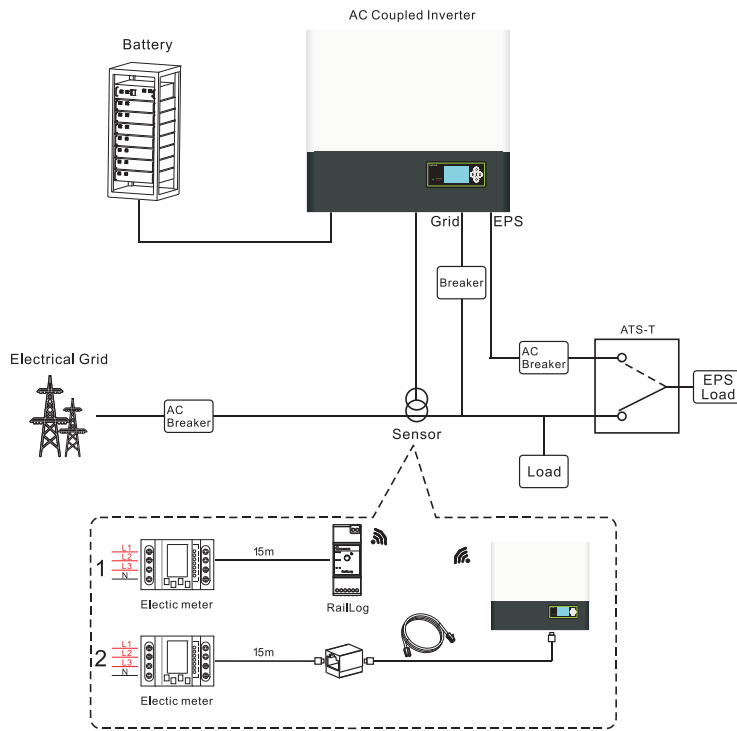
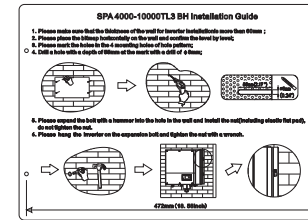

Chart 5.7

5.3.2 Installation of SPA

1. First estimate the size of the inverter on the wall;
2. Determine the location of the drill hole through the cardboard (installation guide), put the cardboard on the wall and make sure the top edge of the cardboard is horizontal.
3. Mark four points at the wall via the hole of the paper board, then remove the cardboard.

4. Drill four $\Phi 8$ holes at the mark point, the depth is not less than 55mm.
5. Knock four explosion bolt into $\Phi 8$ holes (As the chart 5.8b below).
6. Hang the energy storage machine on the four setscrews (As the chart 5.8c below).
7. Lock the nut of setscrew (As the chart 5.8d below).
8. The whole installation has finished.



a)

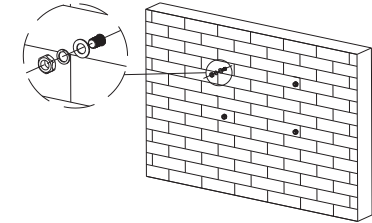

b)

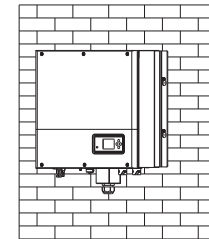

c)

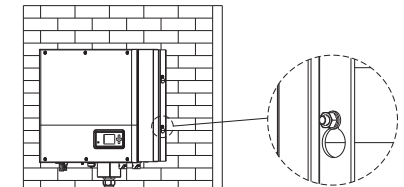

d)

Chart 5.8

5.4 SPA System Connection Mode

5.4.1 Connection of AC terminal and off grid terminal

SPA has a grid output terminal and off grid out terminal, look down on the SPA from the front, the terminal on the left (on grid) is grid outlet for connecting grid, the terminal on the right is an emergency power outlet for connecting critical load.

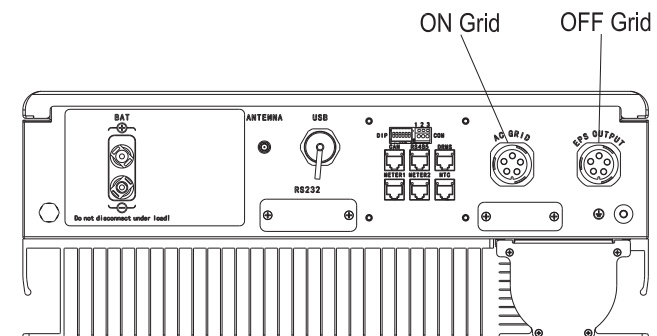

Chart 5.9

Wire suggest length:

conductor cross section	max cable length					
	Growatt SPA 4000 TL3 BH	Growatt SPA 5000 TL3 BH	Growatt SPA 6000 TL3 BH	Growatt SPA 7000 TL3 BH	Growatt SPA 8000 TL3 BH	Growatt SPA 10000 TL3 BH
10AWG	88m	70m	59m	50m	44m	35m
12AWG	55m	44m	37m	31m	27m	22m

AC output terminal and EPS output terminal connection steps as follow:
Step 1: Uninstall the AC terminal as below chart.

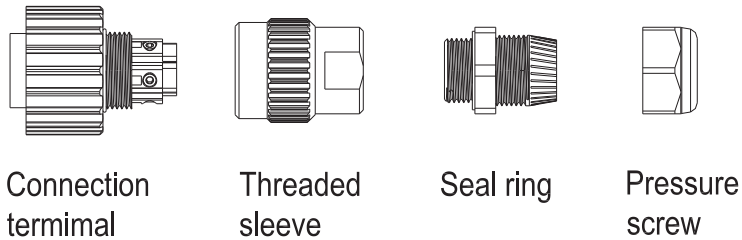

Chart 5.10

Step 2: Thread cables through pressure screw, seal ring, threaded sleeve in sequence, insert cables into connection terminal according to polarities indicates on it and tighten the screws.

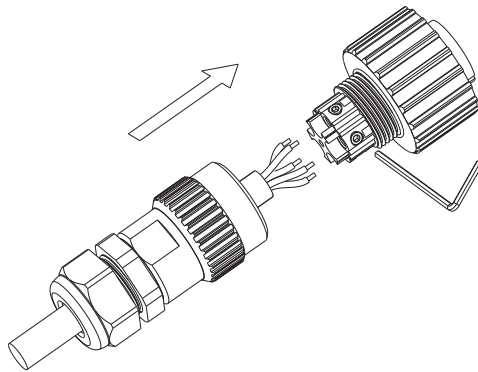

Chart 5.11

Step 3: Push threaded sleeve on to connection terminal until both are locked tightly.

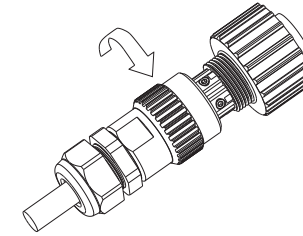

Chart 5.12

Step 4: Plug the socket into AC output terminal, clockwise rotation to tighten the socket, counterclockwise rotation to loosen the socket.

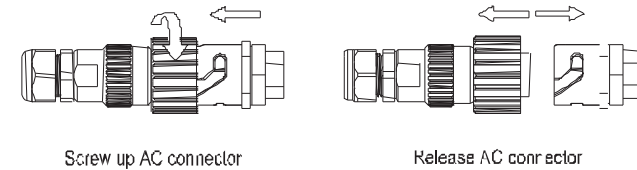

Chart 5.13

The following diagram shows the AC output terminal of the Australian machine connection steps, EPS output terminal connection steps consistent with the above steps.

AC output terminal and EPS output terminal connection steps as follow:
Step 1: Uninstall the AC terminal as below chart.

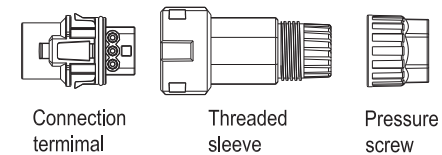

Chart 5.14

Step 2: Thread cables through pressure screw, seal ring, threaded sleeve in sequence, insert cables into connection terminal according to polarities indicates on it and tighten the screws.

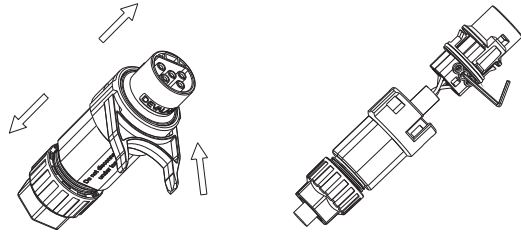

Chart 5.15

Step 3: Push threaded sleeve on to connection terminal until both are locked tightly.

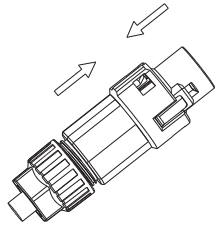
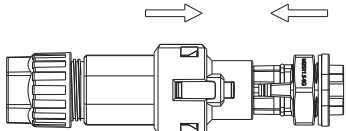

Chart 5.16

Step 4: Plug the socket into AC output terminal until it is locked. Use a flat-blade screwdriver to hold the buckle and pull out the AC terminal.



Screw up AC connector

Chart 5.17

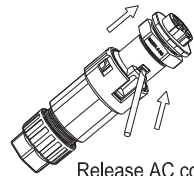

Release AC connector

Step 5: Plug the AC terminal into the inverter AC port.

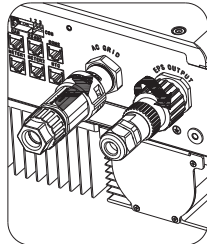

Chart 5.18

The recommended wiring diagram is as follows:

Diagram A

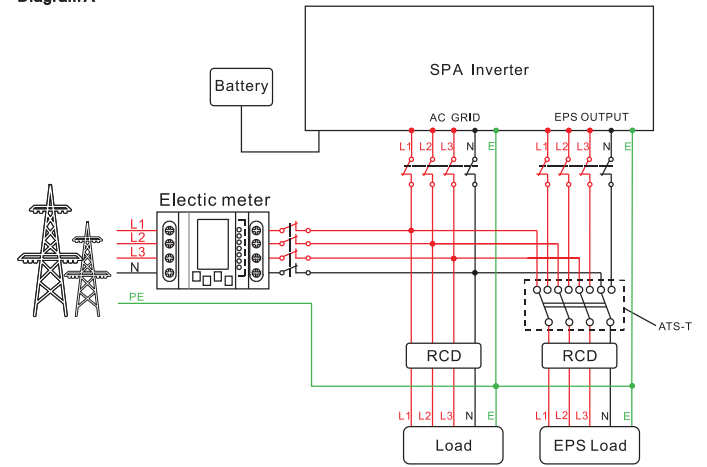

Chart 5.19

Note:
This diagram is an example for grid system without special requirement on electrical wiring connection.

Diagram B

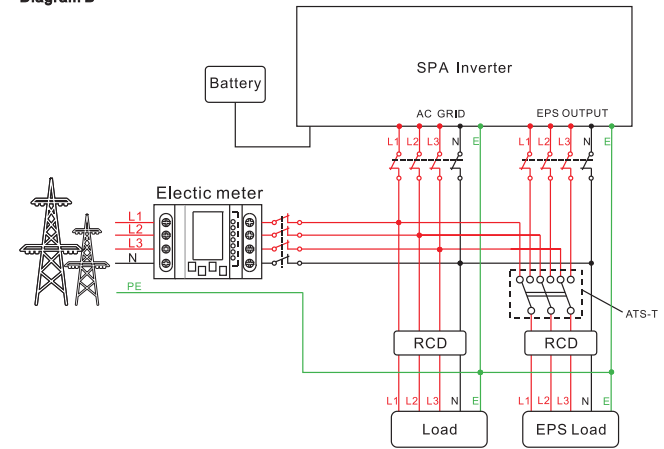

Chart 5.20

Note:
This diagram is an example for Australian and New Zealand grid system where neutral line can't be switched.

5.4.3 Connection of meter terminal

When customer needs to use meter to monitor the energy flow, the meter terminal connection steps are as follows:

- Step1: Reference 5.2, make LAN cables with RJ45 terminal.
- Step2: Thread the swivel nut over the LAN cable.
- Step3: Press the cable support sleeve out of the cable gland.
- Step4: Remove the filler plug from the cable support sleeve.
- Step5: Route the LAN cable through an opening in the cable support sleeve.
- Step6: Thread the LAN cable through the cable gland.
- Step7: Insert the RJ45 plug of the network cable into the "METER-1" pin connector on the inverter until it snaps into place.
- Step8: If no other cables need to be installed, lock the waterproof cover to the inverter with screws.
- Step9: Screw the swivel nut onto the waterproof cover.

Note:

1. Meter must be provided by Growatt. If not, maybe meter can't communicate with SPA inverter.
2. The more detail describe of meter installation, please turn to meter user manual.

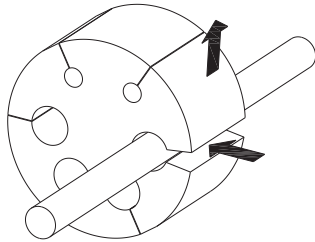

Chart 5.24

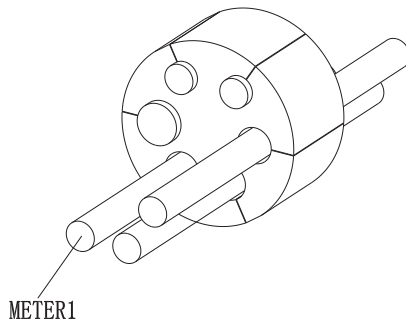

Chart 5.25

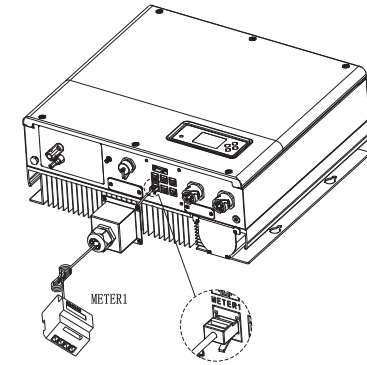

Chart 5.26

Remark:

Meter wire (15m in length) specification: RJ45, standard LAN line (one end with 8P modular plug, the other connected with transformer). But if the length is not enough, customer can add cable, so the length can be increased to 25m max, the operation is as follow chart:

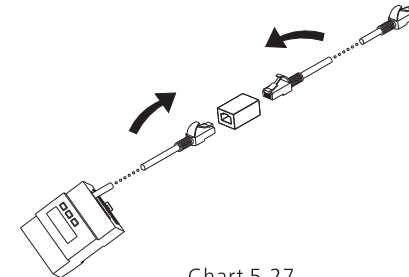

Chart 5.27

5.4.4 Connection of communication terminal for lithium battery (CAN)

When using CAN communication with lithium batteries (for example PYLONTECH X1) , connect lithium battery terminal (RJ45) steps as follows:

- Step1: Unscrew the swivel nut from the cable gland.
- Step2: Thread the swivel nut over the "CAN" cable.
- Step3: Press the cable support sleeve out of the cable gland.
- Step4: Remove the filler plug from the cable support sleeve.
- Step5: Route the "CAN" cable through an opening in the cable support sleeve.
- Step6: Thread the "CAN" cable through the cable gland.
- Step7: Insert the RJ45 plug of the network cable into the "CAN" pin connector on the inverter until it snaps into place.
- Step8: If no other cables need to be installed, lock the waterproof cover to the inverter with screws.
- Step9: Screw the swivel nut onto the waterproof cover.

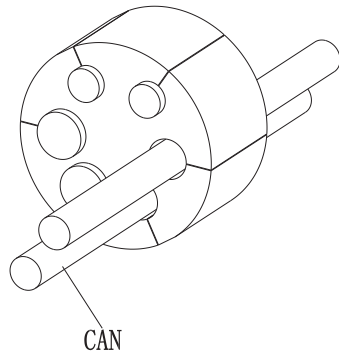

Chart 5.28

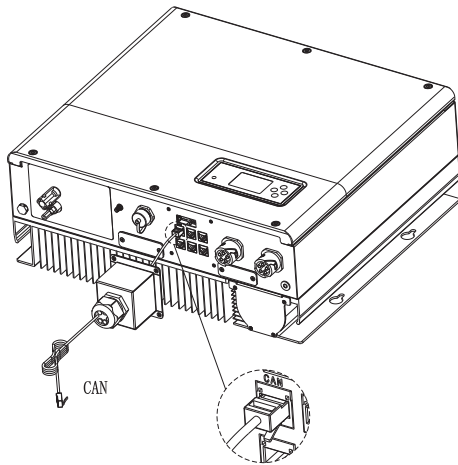

Chart 5.29

Note:

1. If you are using a lead-acid battery, you do not need to install this communication cable.
2. The CAN battery communication and RS485 battery communication can't be installed at same time, please select the correct communication method according to the battery manual.
3. If the cable such as "RS485" cable or "CAN" cable is not used, please do not remove the filler plug from the cable support sleeve.

5.4.5 Connection of RS 485 (reserved) terminal

RS 485 reserved communication interface, can be used for meter communication, please connect the terminal (RJ45) as follows:

- Step1: Unscrew the swivel nut from the cable gland.
- Step2: Thread the swivel nut over the "RS485" cable.
- Step3: Press the cable support sleeve out of the cable gland.
- Step4: Remove the filler plug from the cable support sleeve.
- Step5: Route the "RS485" cable through an opening in the cable support sleeve.
- Step6: Thread the "RS485" cable through the cable gland.
- Step7: Insert the RJ45 plug of the network cable into the "RS485-2" pin connector on the inverter until it snaps into place.
- Step8: If no other cables need to be installed, lock the waterproof cover to the inverter with screws.
- Step9: Screw the swivel nut onto the waterproof cover.

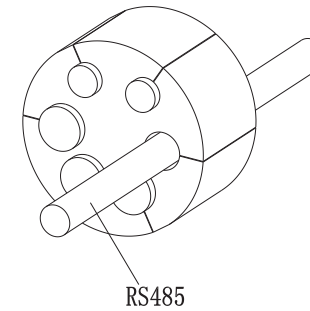

Chart 5.30

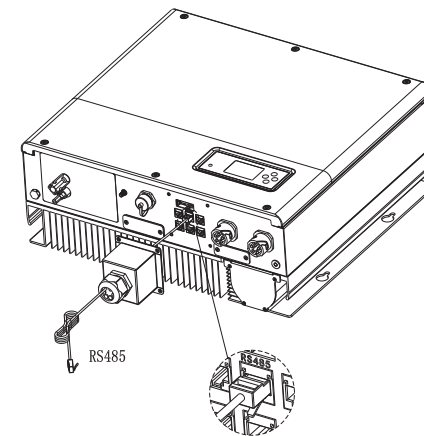

Chart 5.31

5.4.6 Connection of DRMS terminal(Australia only)

When SPA is applied to Australia, the DRMS terminals need to be connected, the connection way appears as follows:

- Step1: Unscrew the swivel nut from the cable gland.
- Step2: Thread the swivel nut over the "DRMS" cable.
- Step3: Press the cable support sleeve out of the cable gland.
- Step4: Remove the filler plug from the cable support sleeve.
- Step5: Route the "DRMS" cable through an opening in the cable support sleeve.
- Step6: Thread the "DRMS" cable through the cable gland.
- Step7: Insert the RJ45 plug of the network cable into the "DRMS" pin connector on the inverter until it snaps into place.
- Step8: If no other cables need to be installed, lock the waterproof cover to the inverter with screws.
- Step9: Screw the swivel nut onto the waterproof cover.

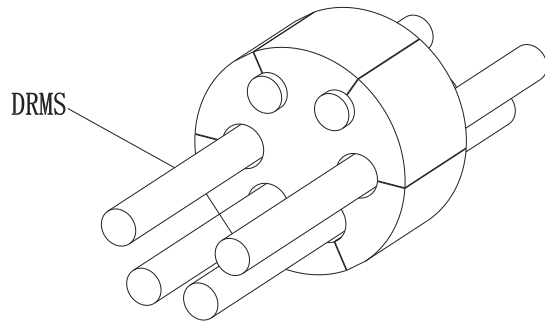

Chart 5.32

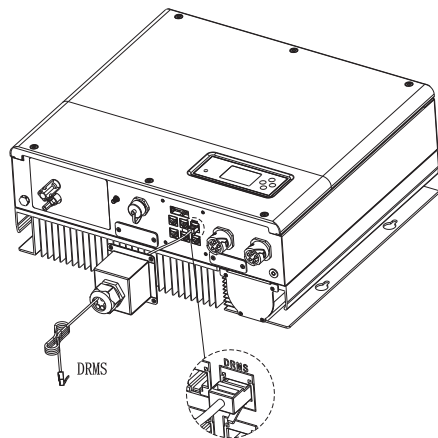

Chart 5.33

RJ45 terminal pin assignment

PIN	assignment for inverter scapable of both charging and discharging
1	DRM5
2	DRM6
3	DRM7
4	DRM8
5	RefGen
6	COM/DRM0
7	/
8	/

Method of asserting demand response modes

MODE	Rj45 socket asserted by shorting pins		Requirement
DRM0	5	6	operate the disconnection device
DRM5	1	5	Do not generate power
DRM6	2	5	Do not generate at more than 50% of rated power
DRM7	3	5	Do not generate at more than 75% of rated power and sink reactive power if capable
DRM8	4	5	Increase power generation (subject to constraints from other active DRMs)

Note:

If the cable such as "NTC" (lead-acid battery temperature sensor) cable is not used, please do not remove the filler plug from the cable support sleeve.

5.4.7 Connection of temperature probe for lead-acid battery

When customer using lead-acid battery, the temperature probe of the lead-acid battery is used to detect the ambient temperature of the lead-acid battery, the battery temperature cable of the SPA side connection steps are as follows:

- Step1: Unscrew the swivel nut from the cable gland.
- Step2: Thread the swivel nut over the "NTC" cable.
- Step3: Press the cable support sleeve out of the cable gland.
- Step4: Remove the filler plug from the cable support sleeve.
- Step5: Route the "NTC" cable through a min opening in the cable support sleeve.
- Step6: Thread the "NTC" cable through the cable gland.
- Step7: Insert the RJ45 plug of the network cable into the "NTC" pin connector on the inverter until it snaps into place.
- Step8: If no other cables need to be installed, lock the waterproof cover to the inverter with screws.
- Step9: Screw the swivel nut onto the waterproof cover.