

Chart 5.34

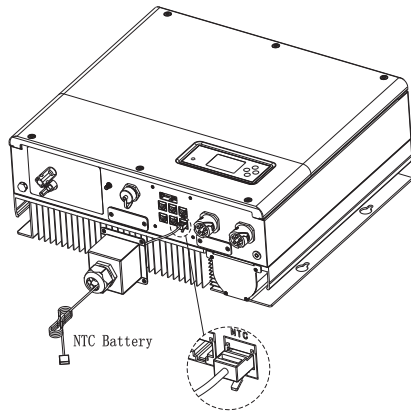

Chart 5.35

Note:

1. If you are using a lithium battery, you do not need to install this temperature probe, the probe of the temperature cable should be attached to the surrounding environment of the lead-acid battery, and the length of this cable is 1.5m, so pay attention to the distance of battery and SPA.
2. If the cable such as "NTC" (lead-acid battery temperature sensor) cable is not used, please do not remove the filler plug from the cable support sleeve.

5.4.8 Connection of Dry contact

The dry contact is used to communicate with external devices (such as remote start hot water heater). The wiring steps are as follows:

- Step1: Unscrew the swivel nut from the cable gland.
- Step2: Thread the swivel nut over the cable.
- Step3: Press the cable support sleeve out of the cable gland.
- Step4: Remove the filler plug from the cable support sleeve.
- Step5: Route the network cable through an opening in the cable support sleeve.
- Step6: Thread the network cable through the cable gland.
- Step7: Thread cables into connection terminal of the inverter, then press the terminal by relevant tools and make sure cables are firmly.

Step8: If no other cables need to be installed, lock the waterproof cover to the inverter with screws.

Step9: Screw the swivel nut onto the waterproof cover.

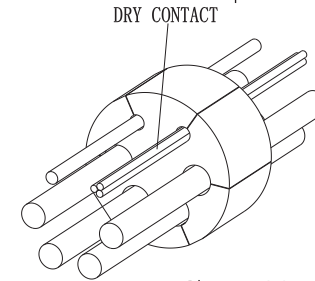

Chart 5.36

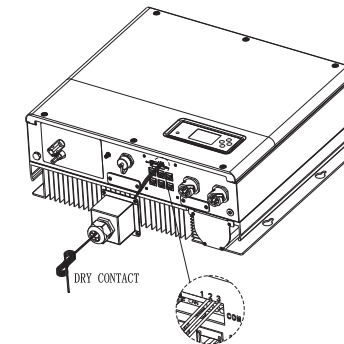

Chart 5.37

Note:

If the cable such as "Dry contact" cable is not used, please do not remove the filler plug from the cable support sleeve.

5.4.9 Grounding connection

SPA must be grounded by cable, the grounding point is showed as follow, and the minimum grounding cable wire diameter is 10.0mm².

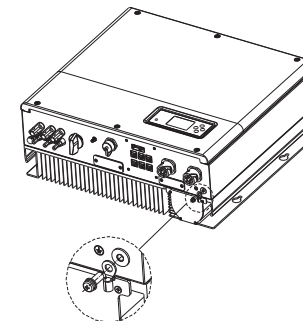

Chart 5.38

6 Commissioning

6.1 Commissioning of SPA

Electrify SPA after all installation of Part5 be finished, here are the steps:

- Connect AC
- Connect battery
- Turn on AC first
- Then turn on battery

If Grid and battery are available, system would work on the "normal" mode. When the SPA on the normal mode, the screen showing "normal", LED is green, if SPA not enter normal mode successful, especially the LCD is red, you need to check below:

- Make sure all the connection is correct.
- All the external switches are on.
- Inverter built -in switch is on.
- Make sure the lithium battery is on.
- Refer to Part 9.1 for correction.

You can refer to Part 6.4.4 for work mode setting, then configure monitor, finish commissioning.

6.2 Operation modes

6.2.1 Normal mode

Normal mode is working state which including online mode and backup mode.

• Online mode

User can set an appropriate priority mode according to request when SPA working on the online mode. If customer uses the LCD and key settings, you can only set one period, but if you use website settings, you can set up to three periods of the priority mode. (Refer to 6.4.4)

Load first: Load first is the default mode.

- With inverter in the SPA system, energy from inverter optimize load, then charge battery, exceed power export to the grid.
- Without inverter or the energy from inverter is weak, the battery will discharge for load firstly and the grid will supply the power when the battery power is not enough.

Battery First: When SPA series working under this mode, battery would be charged first, it's suitable working on the period when the electric charge is low. User need to set the mode ON and OFF time, and the end time of battery SOC. Users can set power rate which less than the battery maximum output power.

- With inverter in the SPA system, energy from inverter charge battery, then load and the grid will supply the power when the inverter power is not enough.
- Without inverter or the energy from inverter is weak, the grid will charge the battery and load.

Grid first: When SPA series working under Grid-first mode, the battery energy would feed to Grid first. User can choose the period when electric charge is high. User need to set the mode ON and OFF time, and the end time of battery SOC. User can set power rate which less than the battery maximum output power.

- With inverter in the SPA system, battery discharge to load. If the sum of inverter power and battery power is greater than the load, excess power flows to the grid.
- Without inverter or the energy from inverter is weak, battery discharge to load and excess power flows to the grid.

• Backup mode

If the grid lost, system would turn to backup mode (user can disable it, refer to 6.4.4) and AC output is from EPS port. All of the energy is from battery. SPA maximum output power is SPA nominal power in this mode, the load which connect with EPS port should be less than SPA nominal power. Mind you, SPA maximum output power is 10000W in this mode, the load which connect with EPS LOAD should less than 10000W.

NOTICE:

User only can set one period for battery first and Grid first on the LCD, if user need set more please login shineserver.

If user needs Grid charge battery, user need input password on the SC surface and set the AC CHG to enable.

6.2.2 Fault mode

The SPA's intelligent control system could monitor and adjustment system's status continuously, when SPA inverter monitoring anything unexpected happen, such as system fault or machine fault, the LCD will display the fault information, in fault mode, the LED light will be lighten.

NOTICE:

- The detail's fault information please refer to 9.1
- Some fault information is in order to remind users that might have some faults occurred in inverter side.

6.2.3 Programming mode

Programming mode indicates the SPA is updating, don't cut out power when it's updating until the processing is finish, SPA inverter would log out automatically when the updating finish and turn to other mode.

6.2.4 Checking mode

Before SPA work in normal mode, it will go to self-check mode. If all are ok, system will go to normal mode, otherwise, it will go to fault mode.

6.2.5 Standby mode

If the system hasn't faults while the condition is not qualified, SPA would stay at standby mode.

6.2.6 Shutdown mode

If customer need SPA inverter stop working, customer must disconnect all the energy source, then SPA inverter will turn into shutdown mode automatically. The following is the shutdown procedure:

- > Turn off battery switch.
- > Shut down AC power of SPA. Then you can see the both LED and LCD of SP are off.

NOTICE:

After all the actions are done, you still have to wait for more than 5 minutes.

6.3 Country setting

Growatt can provide various regulations of the machine, after customers receive the machine, according to their country, by dialing DIP switch to set the corresponding regulations. Following is the DIP switch introduction.

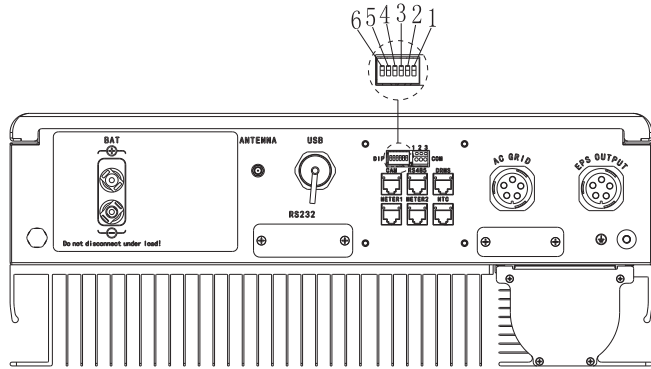

Chart 6.1

 DANGER	<p>Caution :</p> <p>When you setting the DIP, you must turn off AC breaker and Battery to make sure all of the power are off.</p>
	<p>Caution:</p> <p>1. After setting the DIP, please power on the inverter and check the model display (show as 6.3.1). If the model display is match what you want, it means your setting is successful.</p> <p>2. You need to calibrate the time that the machine is showing after inverter starts up.</p> <p>If the country is set incorrectly, please shut down the inverter and set again.</p>

The DIP switch is composed of five-digit binary number PINS. The different combination of the five PINS can represent different inverter's model, which is corresponding to the local grid standard. Each small white PIN has two statuses, when set upward to "ON", its value turns to "1", when set downward, its value turns to "0". Concerning the matching of the PIN status and the country safety standard, please refer to the table below:

6.3.1 Switch to country table

DIP switch status	Country/region / regulations	Model display
	VDE 0126	GT0XXXXXX1
	Queensland	GT0XXXXXX2
	AS 4777	GT0XXXXXX3
	CEI 0-21	GT0XXXXXX4
	Greece	GT0XXXXXX6
	VDE-AR-N 4105	GT0XXXXXX7
	G98	GT0XXXXXX8

	EN50438-Norway	GT0XXXXXX9
	EN50438-Poland	GT0XXXXXXB
	Hungary	GT0XXXXXXC
	Belgium	GT0XXXXXXD
	Thailand MEA	GT0XXXXXXE
	Thailand PEA	GT0XXXXXXF
	Spain	GT1XXXXXX0
	CQC-1	GT1XXXXXX1
	TAIWAN	GT1XXXXXX2

	EN50438-Ireland	GT1XXXXXX3
	India	GT1XXXXXX4
	Brazil	GT1XXXXXX5
	EN50438-Sweden	GT1XXXXXX6
	Denmark1	GT1XXXXXX7
	AS4777-NEW Zealand	GT1XXXXXX8
	France	GT1XXXXXX9
	Denmark2	GT1XXXXXXB
	EN50549	GT1XXXXXXD

6.4 Display and button

6.4.1 LCD display area

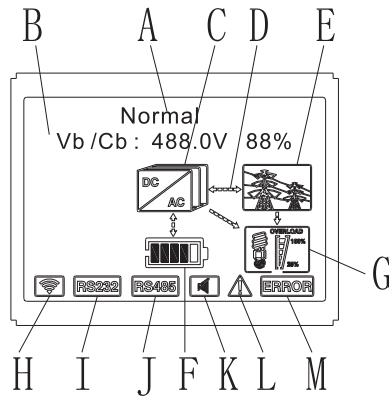

Chart 6.2

Location	Description
A	State
B	Information
C	SPA inverter
D	Power flow line
E	Grid
F	Battery (show the SOC in five grid, Every grid represents 20%)
G	Local load
H	Wireless communication
I	RS232
J	RS485
K	Buzzer(Reserved)
L	Warning
M	Fault

6.4.2 LED and button instruction

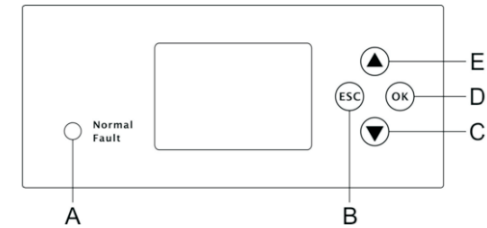

Chart 6.3

Location	Description
A	Status
B	ESC - button(cancel control)
C	Down-button
D	Enter-button
E	UP-button

Notice:

LED showing status of SPA, it has two colors, one is green and another is red. Please turn to 3.1 and read the detail of LED.

6.4.3 LCD display column

LCD display column is used to show the current state, basic information and fault information. Also includes language setting, program charging/discharging priority and system time. On default condition will take turns to display the information.

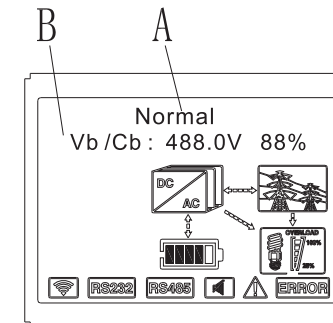

Chart 6.4

The A line's concluding information as follow:

- Standby state: SPA is in standby state. No error in this state, but for other reasons, make it in a wait state.
- Normal state: SPA is normal working state.
- Checking state: SPA is in self-check state, if there is no error or warning, SPA will go to normal state or standby state. Otherwise it will go to fault state.
- Programming state: SPA is in updating firmware state.
- Fault state: SPA has fault information, it will be in stopped operational protection state.

The B line's information as follow:

In normal, it will turn on page automatically, when pushing the button "UP", the order of the paging information as follow:

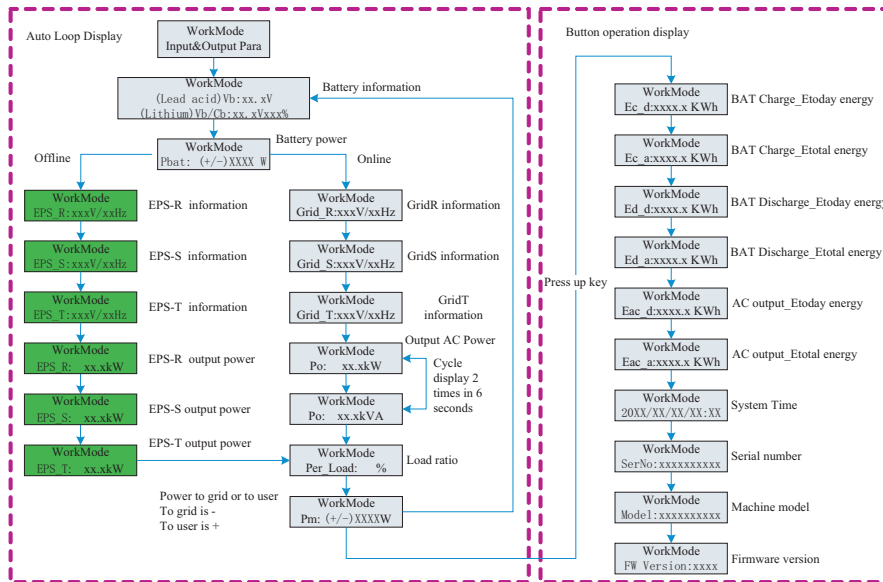

Chart 6.5

Note:

- "Down" control command (if press "up" button, command will go back).
- Workmode depend on the situation. If SPA is normal state, it will show "normal". If SPA is standby state, it will show as "standby" etc.
- Some special definitions are explained, for example: Vb means the voltage of battery. Cb means the capacity of lithium battery (only lithium battery shows this data). Pm means the monitor power of user.

6.4.4 work mode set up

You can enter set up page by long press "enter" for 3S, in this page, you can press "enter" or "ESC" for 1S to finish the selection, the page shows like following:

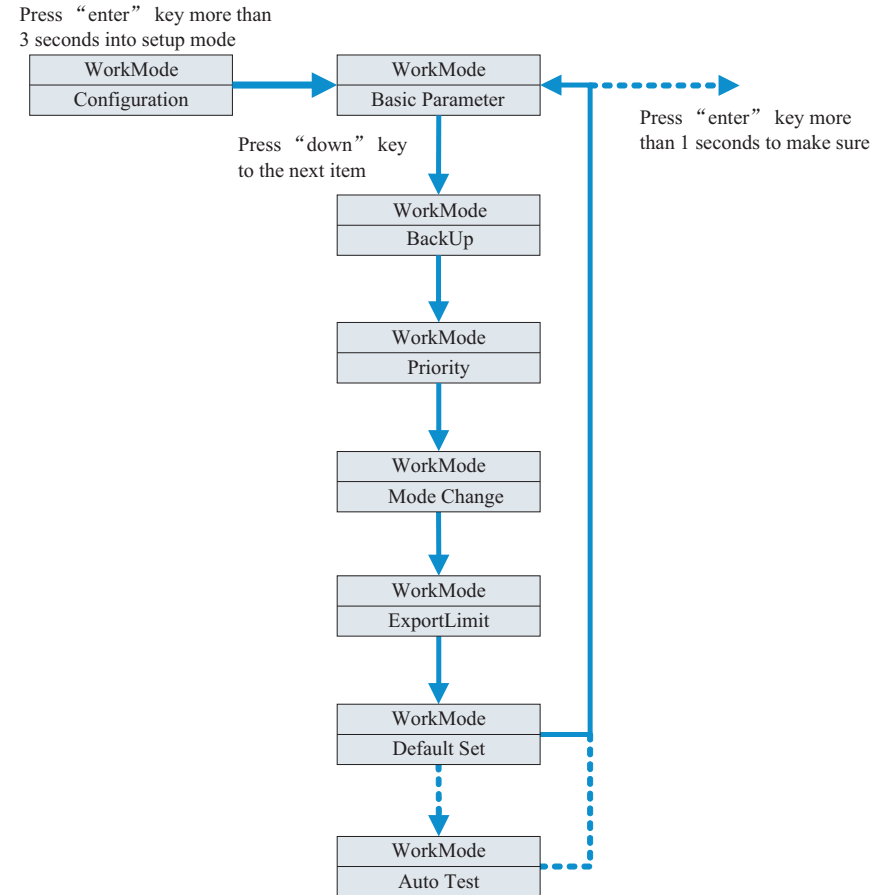

Chart 6.6

If you choose CEI and used SPA inverter in Italy, SPA inverter have Auto Test function. How to use the Autotest functions. Please see the annex.

1. Under the Basic Para, you can see the setup options below after pressing Enter for 1S:

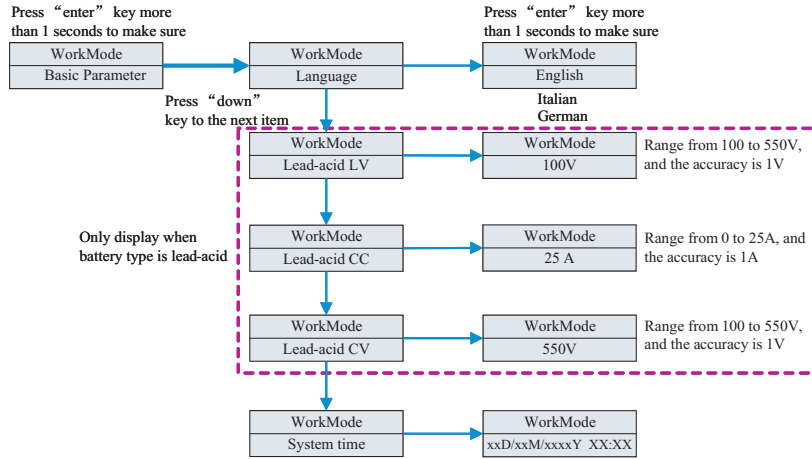

Chart 6.7

In the basic Parameter, you can set language (English, Italian, German), system time, Lead-acid CV (default is 550V), Lead-acid LV (default is 100V), Lead-acid CC (default is 25A).

2. Under the Back Up, you can see the setup options below after pressing Enter for 1S:

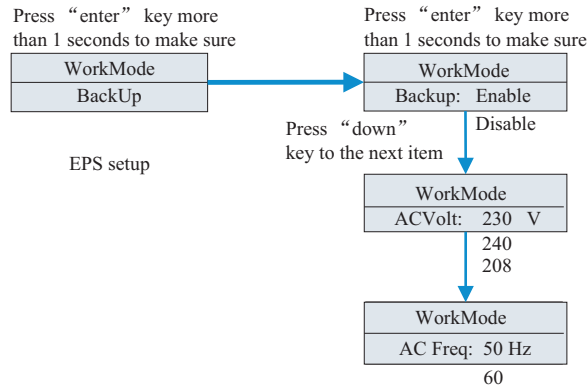

Chart 6.8

In the back up you can set EPS, including enable or disable (default is enable), AC voltage (default is 230V) and frequency (default site 50HZ).

3. Under the Priority, you can see the setup options below after pressing Enter:

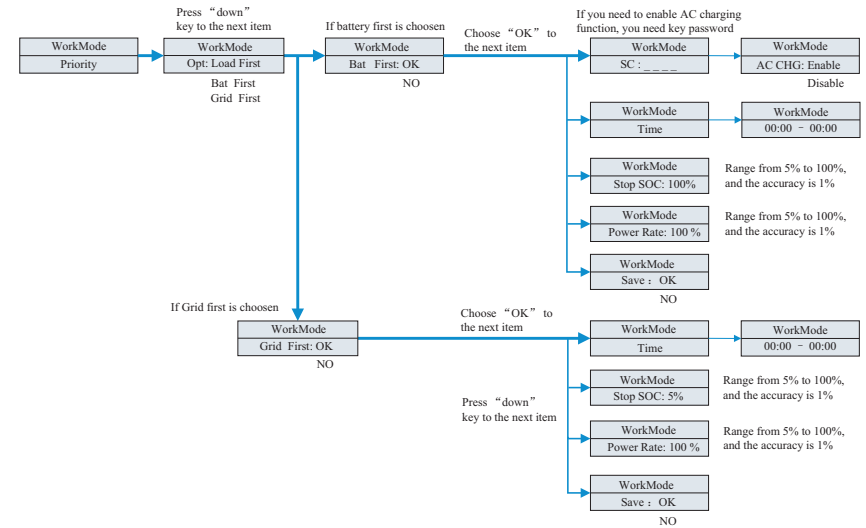

Chart 6.9

Note:

- “Power Rate” is used to set up power of battery. So different battery may have the different power, customer need to check the max power of battery.
- Time setting is 24-hour. If the end time is less than beginning time, it defaults to spanning days.

4. Under the Mode Change, you can see the setup options below after pressing Enter:

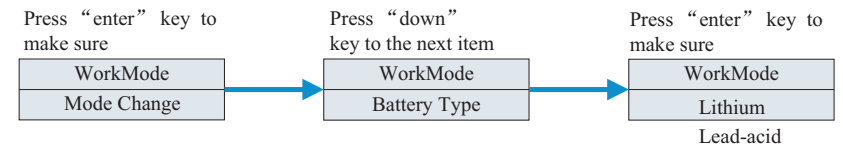

Chart 6.10

The Mode change has two options what are sensor and battery type, sensor is meter (default). In the battery type, you can choose lithium battery or lead-acid battery.

5. Under the Export Limit, you can see the setup options below after pressing Enter:

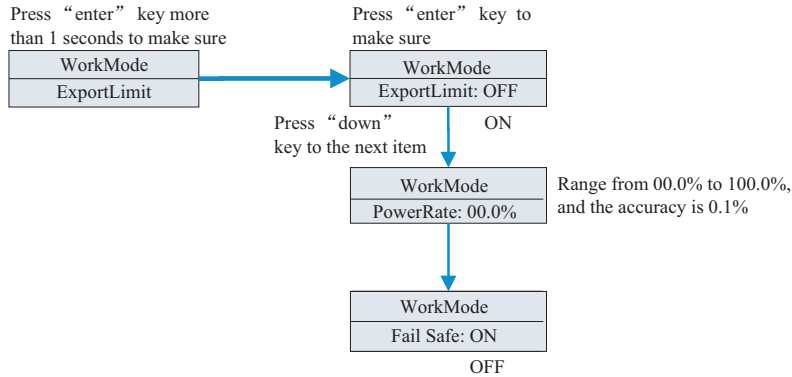

Chart 6.11

Export Limit is used for users to control the energy flowing to the grid. If this function is enabled, the feeding power to grid will be equal or less than the setup value. The purpose of the Fail Safe function is to ensure that should any part of the ELS fail, the Active Power exported across the Connection Point will drop to the Agreed Export Capacity or less within within the specified time.

Note:

- Default value is 00.0%.

6. Under the default set, you can see the setup options below after pressing Enter:

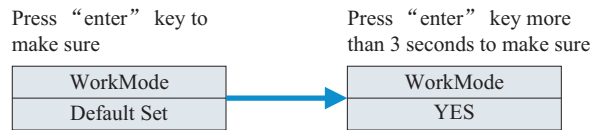

Chart 6.12

Default set is "resume to default setting", please don't use it unless it's necessary.

6.5 Communication

6.5.1 Use of USB-A port

USB-A port is mainly for firmware update. Through USB connection, we can quickly update the software of machine. You can see USB-A as below:

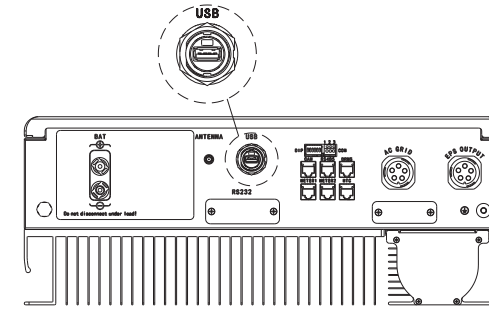

Chart 6.13

Note: USB is only used for firmware update. Customer can't use it for charging.

6.5.2 Use of RS232 port

RS232 port is mainly used for monitoring connection with computer, users can monitor, set parameters and update the software of the machine through RS232 connection with machine and PC, using the shinebus software developed by Growatt. About ShineBus software, when you needed, please download from official website of Growatt.



Chart 6.14

Before use RS232 communication, you should make sure the follow PIN1 and PIN2 are off:

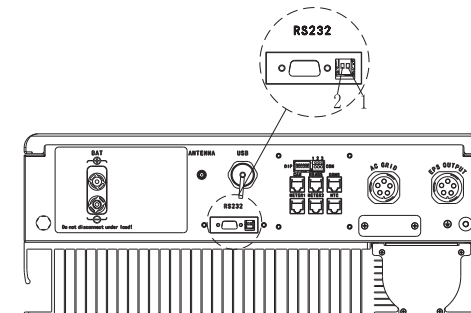

Chart 6.15

Start-up and shut down SPA system 7

The wiring diagram is as follows:

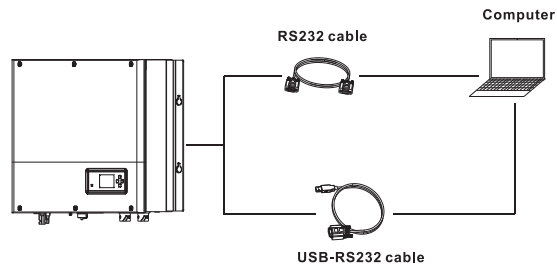

Chart 6.16

6.5.3 The SPA's monitoring

The SPA provide RS232 interface. Users can through the following communication solution to monitor the SPA.

Note:

This monitoring devices can only be used with Growatt's Shineserver / shinephone monitor platform. Wi-Fi-S / Shinelink are connect with inverter via RS232 interface and use computer terminal / or mobile phone for data monitoring.

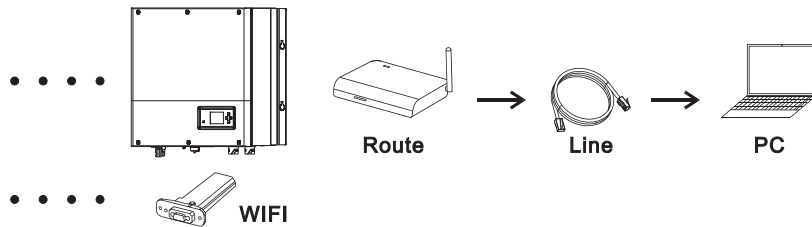

Chart 6.17

Before use WIFI communication, you should make sure the follow PIN1 and PIN2 are ON:

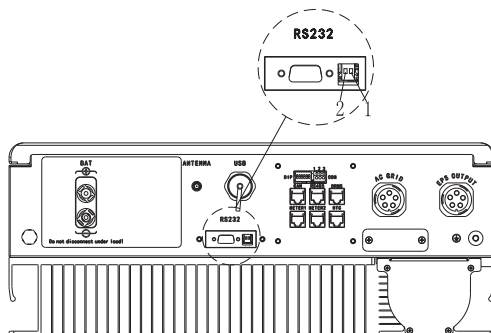

Chart 6.18

7.1 Start-up the SPA system

Users can start-up SPA inverters through following steps:

- 1.Connect to Grid.
- 2.Connect to Battery.
- 3.Turn the switch on in turn of Grid, battery.
- 4.When the LED turns green, the working information on LCD indicates the successful start-up of SPA inverter.

7.2 Disconnect the SPA system

1. Turn off all the circuit breaker and switch.
2. Disconnect the inverter.
3. Disconnect the battery.
4. Pull up AC PLUG connection.
5. Waiting until LED, LCD display have gone out, the SPA is shut down completely.

8 Attention of the installation environment, maintenance and cleaning

Heat dissipation performance is very important when SPA inverter work under the environment of high temperature, better heat dissipation can reduce the possibility of SPA inverter stops working. Growatt SPA series inverter without fan so belongs to natural cooling, hot air from the top of the radiator, tie-in battery, use environment for IP65, please pay attention to the temperature of the installation environment, to ensure that the battery's safety and the normal work of the machine.

When use battery, please pay attention to the follow information:

Caution: Do not dispose of batteries in a fire. The batteries may explode.

Caution: Do not open or damage batteries. Released electrolyte is harmful to the skin and eyes. It may be toxic.

Caution: A battery can present a risk of electrical shock and high short-circuit current.

The following precautions should be observed when working on batteries:

- Use watches, rings or other metal objects.
- Use tools with insulated handles.
- Wear rubber gloves and boots.
- Do not lay tools or metal parts on top of batteries.
- Disconnect charging source prior to connecting or disconnecting battery terminals.
- Determine if battery is inadvertently grounded. If inadvertently grounded, remove source from ground. Contact with any part of a grounded battery can result in electrical shock. The likelihood of such shock can be reduced if such grounds are removed during installation and maintenance (applicable to equipment and remote battery supplies not having a grounded supply circuit).

If SPA inverter doesn't work for overheating or too cold, solve it according to the following methods:

- Confirm whether the radiator air duct installation is reasonable, choose the appropriate position before installation.
- If lead-acid batteries are connected, confirming the NTC battery is in a good installation.
- Confirm whether the battery temperature is too high, too high temperature of battery can also lead to SPA fail to work, at this point, to ventilation, cooling or still handle to the battery, please.
- If temperature is low, also can appear the battery low temperature protection, the battery will start with small load in low temperature output, after temperature back to normal system can work normally, please be patient at this time.
- If the temperature is too low, it is possible that battery will be low temperature protection, at this time, please pay attention to the working temperature range listed in the specifications of the book.
- Servicing of batteries should be performed or supervised by personnel knowledgeable about batteries and the required precautions.
- When replacing batteries, replace with the same type and number of batteries or battery packs.
- General instructions regarding removal and installation of batteries.

Remark:

All of above action should be operated by professional person, if you want to do these works, you must make sure the whole system are off.

Fault removal 9

Our products are carried out with strict tests before they take out, if the operation difficulties in the process of installation, please log on to www.ginverter.com website, view the Q&A program.

When SPA inverter fault happens, please inform our company, and to provide SPA related information, we will have a professional after-sales service personnel to answer you.

What you need to provide the information about the SPA including:

- Serial number.
- Model.
- Information about the LCD display.
- Brief description of problems.
- The battery voltage.
- The grid voltage and frequency.
- Can you retell the failure problem? If you can, what kind of a situation.
- Did the problem happen in the past?
- When did this fault happen? First installation?

About the battery:

- The manufacturer name and model of battery.
- Capacity of battery.
- Output voltage of the battery.
- The time you buy Battery and frequency you use it.

9.1 System fault information list and troubleshooting suggestions

Warning Message		
Error message	Description	Suggestion
Warning401	Meter Communication fault	Check the wire connection between meter and inverter is good or not.
Warning506	Battery temperature out of specified range for charge or discharge	Check the environment temperature of battery is in the range of specification or not.

AC V Outrange	Grid voltage fault. Please refer to the local grid standard for more details of the grid frequency.	1.Check the AC voltage is in the range of standard voltage in specification. 2.Check the grid connection is good or not.
AC F Outrange	Grid frequency fault. Please refer to the local grid standard for more details for the grid voltage.	1.Check the frequency is in the range of specification or not. 2.Restart inverter. 3.Please contact Growatt service center if restart can't solve the problem.
BMS COM Fault	Communication fault	1.Check the lithium Battery is open or not. 2.Check the connection of lithium Battery and inverter is good or not.
Battery reversed	Battery terminals reversed	Check the positive and negative of battery is reversed or not.
BAT NTC Open	NTC open (only for lead-acid battery)	1.Check the temperature of lead-acid battery is installed or not. 2.Check the temperature of lead-acid battery is connected well or not.
Battery Open	Battery terminal open (only for lithium battery)	1.Check the battery connection is good or not. 2.Check the switches between the battery and inverter are all on or not.
Over load	EPS output overload warning. If this warning occurred three time. Off-grid function will be locked one hour and output power again.	Please reduce the load of EPS output.
No AC Connection	No Utility	1.Please confirm grid is lost or not. 2.Check the grid connection is good or not. 3.Check the switches on the cable are on or not.
Output High DCI	Output DC current too high. Please refer to the local grid standard for disconnection time when the output DC current is too high.	1.Restart inverter. 2.Please contact Growatt service center if restart can't solve the problem.

Bat Voltage High	Battery Voltage higher than 560V	1.Check the voltage of battery is in the range of specification or not. 2.Check the battery connection is right or not If battery is really higher than 560V. Please disconnect the connection of battery and check inverter.
Bat Voltage Low	Battery Voltage Lower than 100 V	1.Check the real voltage of battery. 2.Check the wire of battery and inverter is good or not.
BMS Warning:XXX	BMS report warning	1.Check the warning information from lithium battery user manual. 2.Please contact Growatt service center if restart can't solve the problem.
BMS error:XXX	BMS report error	1.Check the warning information from lithium battery user manual. 2.Please contact Growatt service center if restart can't solve the problem.
EPS Volt Low	EPS output voltage low	1.Check the load of EPS. If overload occurred, reduce load. 2.Restart inverter again.

Error message		
Error message	Description	Suggestion
Error 411	Internal communication failed	1.Restart inverter. 2.Please contact Growatt service center if restart can't solve the problem.
Error 418	DSP and COM firmware version unmatch, system fault.	1.Read DSP and COM firmware version from LCD or shinebus. 2.Check if the firmware is correct.
Error 303	Inverter L N reversed or ground failed	1.Check the connection of battery and inverter is good or not. 2.Check the PE of inverter is good or not.
Error 405	Relay fault	1.Restart inverter. 2.Please contact Growatt service center if restart can't solve the problem.

Error 407	Autotest failed (only in Italy)	1.Restart inverter. 2.Please contact Growatt service center if restart can't solve the problem.
OP Short Fault	EPS Output Short Fault	1.Check the load of EPS. 2.Check the output of EPS. Especial not connect to grid.
NTC Open	Internal temperature failed	Please contact Growatt service center
Error 406	Model set up not meet with certification	Please check model set or check the DIP setting
Residual I High	Leakage current too high	1.Check the cable of inverter. 2.Restart inverter. 3.Please contact Growatt service center if restart can't solve the problem.
Error 408	Temperature over range	Please check the temperature is in the range of specification or not.

10 EU Declaration of Conformity

With the scope of EU directives:

- 2014/35/EU Low Voltage Directive (LVD)
- 2014/30/EU Electromagnetic Compatibility Directive (EMC)
- 2011/65/EU RoHS Directive and its amendment (EU)2015/863

Shenzhen Growatt New Energy Technology Co. Ltd confirms that the Growatt inverters and accessories described in this document are in compliance with the above mentioned EU directives. The entire EU Declaration of Conformity can be found at www.ginverter.com.

11.1 Dismantling the energy storage

- 1.Disconnect the SPA inverter such as mentioned in section 7.
- 2.Disconnect the upper cable of SPA inverter.



Watch out the SPA's shell heat and prevent to scald
Wait 20 minutes until the SPA cooling and then to disassembly!

- 3.Unscrew all the connecting cable.
- 4.Unscrew the radiator and wall-mounted anchor screw and then take down the machine from wall.

11.2 Packing the SPA inverter

Usually placed SPA inverter in the packing box with tape sealing, If the SPA inverter cannot reoccupy, You can choose a cheap carton for packaging. Carton requirements must meet the size of the inverter and can support energy storage machine overall weight.

11.3 Storing SPA inverter

Store SPA inverter in a dry place where ambient temperatures are always between -25°C and +60°C.

11.4 Disposing of the SPA inverter



Do not dispose of SPA inverter together with household waste. Please accordance with the disposal regulations for electronic waste which apply at the installation site at that time. Ensure that the old unit and, where applicable, any accessories are disposed of in a proper manner.

12 Product specification

12.1 Growatt SPA series energy storage machine product specification

Model	SPA 4000 T13 BH	SPA 5000 T13 BH	SPA 6000 T13 BH	SPA 7000 T13 BH	SPA 8000 T13 BH	SPA 10000 T13 BH
Specifications						
AC Input/Output data						
AC nominal power	4000W	5000W	6000W	7000W	8000W	10000W
Max. AC apparent power	4000VA	5000VA	6000VA	7000VA	8000VA	10000VA
Nominal AC voltage/range	230V/400V; 310~476V					
AC grid frequency/range	50/60Hz; 45~55Hz/55~65 Hz					
Max. output current	6.1A	7.6A	9.1A	10.6A	12.1A	15.2A
Power factor(@nominal power)	1					
Adjustable power factor	0.8leading ~ 0.8lagging					
THDi	<3%					
AC grid connection type	3W+N+PE					
Stand alone(AC power)						
AC nominal output power	4000W	5000W	6000W	7000W	8000W	10000W
Max. AC apparent power	4000VA	5000VA	6000VA	7000VA	8000VA	10000VA
Nominal AC voltage	230V/400V					
Nominal AC frequency	50/60Hz					
Max. output current	6.1A	7.6A	9.1A	10.6A	12.1A	15.2A
THDV	< 3%					
Switch time	< 0.5S					
Battery data (DC)						
Battery voltage range	100~550V					
Max. charging / discharging current	25A					
Type of battery	lithium battery / Lead-acid battery					
Capacity of battery	5~50kWh					
Efficiency						
MAX. Battery charge/discharge efficiency	97.4%	97.4%	97.4%	97.4%	97.4%	97.4%
Protection devices						
Battery reverse protection	yes					

Insulation resistance monitoring	yes
AC surge protection	Type II
AC short-circuit protection	yes
Ground fault monitoring	yes
Grid monitoring	yes
Anti-islanding protection	yes
Residual-current monitoring unit	yes
General data	
Dimensions (W / H / D)	505*453*198mm
Weight	25kg
Operating temperature range	- 25 °C ~ +60 °C(-13 °F ~ +140 °F) With derating above 45 °C(113 °F)
Noise emission (typical)	≤ 35 dB(A)
Altitude	3000m
Self-Consumption	<13W
Topology	Transformerless
Cooling	Natural
Protection degree	IP65
Relative humidity	0~100%
AC connection	Connector
Battery connection	H4 / MC4 (optional)
Interfaces	
Display	LCD+LED
RS232/RS485/CAN/USB	yes
RF/WIFI/GPRS/4G	optional
Warranty: 5 / 10 years	yes / optional
Certificates and approvals	
Grid regulation	IEC 62040, VDE-AR-N 4105, VDE 0126, UTE C 15-712, EN50549, TR3.2.1, TR3.3.1, CEI 0-21, IEC62116, IEC61727, AS/NZS 4777, G98
EMC	EN61000-6-1, EN61000-6-3
Safety	IEC/EN62109-1, IEC/EN62109-2

Certificate 13

Growatt SPA series inverter apply within the scope of the world, So the inverter have to satisfy different countries and regions of different safety standards.

Model	Certificate
Growatt-SPA series	IEC 62040, VDE-AR-N 4105, VDE 0126, UTE C 15-712, EN50549, TR3.2.1, TR3.3.1, CEI 0-21, IEC62116, IEC61727, AS/NZS 4777, G98, EN61000-6-1, EN61000-6-3, IEC/EN62109-1, IEC/EN62109-2

12.2 DC input terminal parameter

Mc4 specification:

	2.5mm ² /14AWG	4mm ² /12 AWG	6mm ² /10 AWG	10mm ² /8AWG
Rated current (90°C environment)	32A	40A	44A	65A
Nominal system voltage	1000V DC(UL) 1000V DC(TUV)			
Contact resistance	0.25mΩ (model)			
Protection grade	IP68			

Socket contact materials	Copper, tin
Insulation materials	Thermoplastics UL94 V-0
Ambient temperature range	-40°C to +90°C
Wire stripping length	7.0mm(9/32)
Cable casing diameter	4.5 to 7.8mm(3/16: to 5/16")

12.3 Torque

Upper cover screws	1.3Nm(10.8 1bf.in)
Shell and RS232screws	0.7Nm(6.2 1bf.in)
Dc connector	1.8Nm(16.0 1bf.in)
M6 screwdriver	2Nm(18 1bf.in)
Grounding screw	2Nm(18 1bf.in)

12.4 Appendix

The following chart is the energy storage machine optional appendix list, if there is a need please contact the Growatt New Energy Technology Co., Ltd or dealer orders.(P/N is only for reference,and it may be changed)

Name	Description	GROWATT P/N
Shine link	Used for data record in EU	MR00.0007200
	Used for data record in Australia	MR00.0006100
Shine Wi-Fi	Used for data record	MR00.0004601
GPRS	Used for data record	MR00.0009601
ATS-T	Using for on grid and off grid switch auto	TV03.0003200

14 Contact

If you have technical problems about our products, contact the Growatt Service line or dealer. We need the following information in order to provide you with the necessary assistance:

- 1.SPA inverter Serial number.
- 2.SPA inverter module information.
- 3.SPA inverter communication mode.
- 4.SPA inverter fault information code.
- 5.SPA inverter Display content.
- 6.The manufacturer and model of the battery.
- 7.Battery capacity and connection mode.

GROWATT NEW ENERGY TECHNOLOGY Co.,LTD

No.28 Guangming Road, Longteng Community, Shiyao,
Bao'an District, Shenzhen, P.R.China
www.ginverter.com
Serviceline
Tel: + 86 755 2747 1942
Email: service@ginverter.com

Annex:

AutoTest (only for Italy)

Follow is the chart of Auto Test, refer to 6.4.4. in the set up surface of "Auto Test". Press the "enter" key, make sure to start auto test by press "enter" key 3 seconds. The LCD will display the follow message.

